

# IMM QUALITY BOAT LIFTS - ELEVATOR SPECIFICATIONS

## 4,500# - 20,000# Platinum

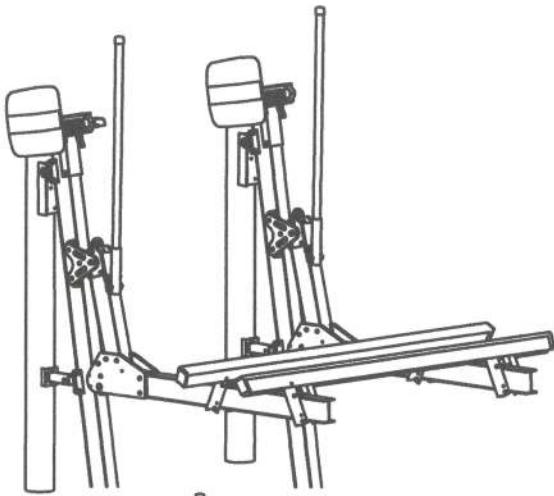

### STRUCTURAL ENGINEERING REVIEW

THIS CONSTRUCTION HAS BEEN DESIGNED AS A MAIN WIND FORCE RESISTING SYSTEM, WITH CALCULATED GRAVITY AND WIND LOADS IN COMPLIANCE WITH THE FLORIDA BUILDING CODE 2014, CHAPTER 16, ADM 2010, AND ASCE/SEI 7-10 "MINIMUM DESIGN LOADS FOR BUILDINGS AND OTHER STRUCTURES" TO WITHSTAND THE WIND LOADS ASSOCIATED WITH AN ULTIMATE WIND SPEED OF 180 MPH, EXPOSURE "D", RISK CATEGORY I. ARNOLD/SANDERS CONSULTING ENGINEERS HAS NO CONTROL OF THE MANUFACTURING, PERFORMANCE, OR INSTALLATION OF THIS PRODUCT. THESE GENERIC DESIGN FEATURES WERE ENGINEERED IN ACCORDANCE WITH ACCEPTED ENGINEERING PRACTICES BASED ON DATA PROVIDED BY THE MANUFACTURER. THIS STRUCTURAL REVIEW IS LIMITED TO THE PRIMARY FRAMING AND CONNECTIONS AND IS NOT INTENDED TO COVER MECHANICAL AND ELECTRICAL COMPONENTS. THESE DESIGN FEATURES ARE BASED ON STRUCTURAL CALCULATIONS, TITLED "STRUCTURAL CALCULATIONS FOR ELEVATOR", WHICH CONTAIN ADDITIONAL DESIGN REQUIREMENTS AND CRITERIA AND ARE AVAILABLE UPON REQUEST. THE BOAT LIFTS DEPICTED BY THESE DESIGNS AND RELATED CALCULATIONS WERE ENGINEERED AS MANUFACTURED PRODUCT FOR NON-SITE SPECIFIC USE AND SHALL MEET THE DESIGN REQUIREMENTS AND INSTALLATION LIMITATIONS LISTED IN THE STRUCTURAL CALCULATIONS - IN PARTICULAR THE TRACK BEAMS SHALL BE ADEQUATELY BRACED AT NO MORE THAN 5 FT. O.C.

Arnold/Sanders Consulting Engineers, Inc.  
 Certificate of Authorization 9451  
 12851 McGregor Blvd., Bldg. 1, Suite 103, Ft. Myers, FL 33919  
 Bus: 239-267-3666

*J. L. Sanders*  
 8-15-16  
 Date: \_\_\_\_\_  
 J. L. SANDERS, P.E.  
 Reg. Florida No. 66361

SIGNATURE NOT VALID WITHOUT RAISED SEAL

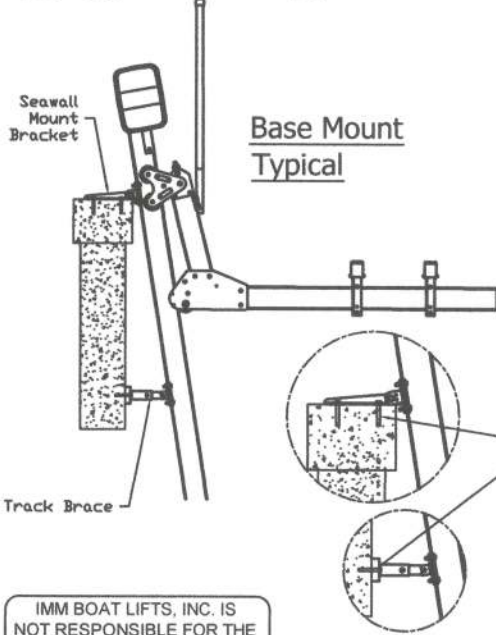

Concrete anchors, 5/8"Ø min stainless steel

### Pile Mount Typical

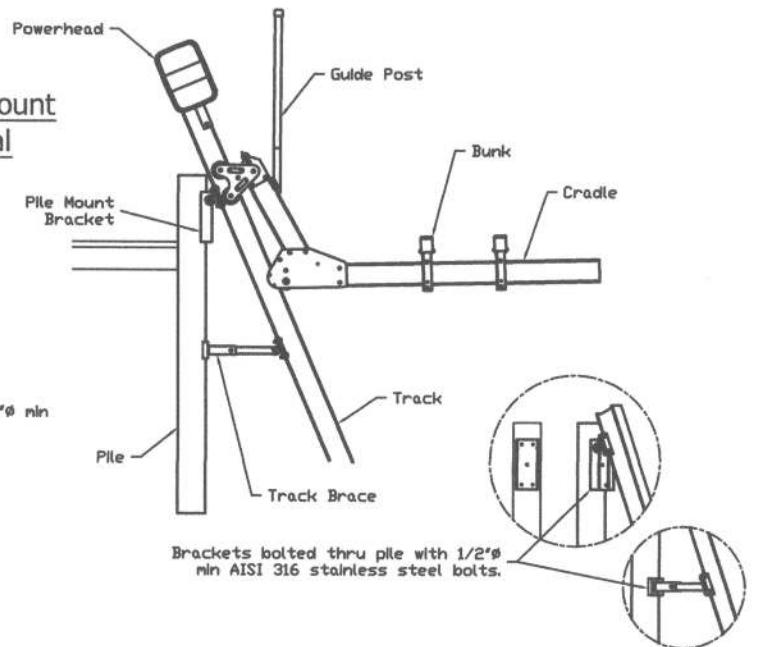

Brackets bolted thru pile with 1/2"Ø min AISI 316 stainless steel bolts.

IMM BOAT LIFTS, INC. IS NOT RESPONSIBLE FOR THE DOCK STRUCTURE OR ITS ABILITY RESIST THE APPLIED LOADS OF THE BOAT LIFT. THE SITE SHOULD BE VERIFIED BY A LICENSED MARINE CONTRACTOR. APPLIED LOADS WILL BE PROVIDED UPON REQUEST.

### Notes:

- Structure designed for loads associated with an ultimate wind speed of 180 MPH, exposure "D", risk category 1, calculated for Florida Building Code 2014, ASCE/SEI 7-10 and ADM-2010.
- Boats shall not be stored on lifts during high wind events.
- All primary structural members to be 6061-T6 aluminum.
- Tracks are to be driven to firm bearing material.
- Wood piles shall comply with ASTM D25 and be southern pine, 2.5 cca marine grade pressure treated.
- Lateral support for piles and attachment to piles shall be engineered by others for site specific conditions.

LIFT CAPACITY	CRADLE I-BEAM	TRACK I-BEAM	TRACK ANGLE OPTIONS	CABLE STD TRAVEL	CABLE EXT TRAVEL	TRACK SPREAD TYP.	GUIDE POST HEIGHT	BUNK BOARD LENGTH	DRIVE SHAFT	WINDER	DRIVE RATIO	MOTOR HP/VOLTAGE	SPEED in/min	STANDARD TRAVEL	EXTENDED TRAVEL
4,500#	6 H x 21 4 W x .35	6 H x 21 4 W x .35 x 25'	0, 10, 23	5/16 SSAC 7x19 304 2-PART 34'	5/16 SSAC 7x19 304 2-PART 49'	108"	80"	12' Aluminum	2.875" O.D. 8 Gauge	3" SCH 80 Pipe	375:1 Platinum	(2) 3/4 HP 115V/230V 22/11 A	26	12'	20'
8,000#	8 H x 23 5 W x .35	8 H x 23 5 W x .35 25'	0, 10, 23	3/8 SSAC 6x36 304 2-PART 34'	3/8 SSAC 6x36 304 2-PART 42'										15'
10,000#	8 H x 25 5 W x .41	8 H x 25 5 W x .41 25'	0, 10, 23	5/16 SSAC 7x19 304 4-PART 58'	5/16 SSAC 7x19 304 4-PART 98'									120"	16' Aluminum
13,500#	10 H x 41 6 W x .25	10 H x 41 6 W x .25 25'	0, 23	3/8 SSAC 6x36 304 4-PART 62'	3/8 SSAC 6x36 304 4-PART 82'	16'									
16,000#	10 H x 50 6 W x .29	10 H x 50 6 W x .29 25'	0, 23												
20,000#	12 H x 62 7 W x .31	12 H x 62 7 W x .31 25'	0, 23									(2) 1-1/2 HP 230V 18A	14		16'